



# PM Cleaning and Component Inspection

## Section 02-01-07

Komatsu has made every effort to make this manual as accurate as possible based on the information available at the time of publication and printing. Continuous improvement and advancement of product design may cause changes to machines, which may not have been included in this publication. Komatsu reserves the right to make changes and improvements at any time. To ensure the most current information please contact your service center.

## Table of Contents

<b>Scope of This Publication .....</b>	<b>3</b>
<b>Safety.....</b>	<b>3</b>
Safety, Warnings and Cautions .....	4
<b>Theory of Operation.....</b>	<b>7</b>
<b>Component Description .....</b>	<b>7</b>
Recommended Washing Equipment – Hot Water High-Pressure Washer or Steam Cleaner.....	7
Additional Recommended Equipment .....	8
<b>Procedures/Processes .....</b>	<b>9</b>
Converter Bus Voltage.....	15
In Cab Verification Using LINCS II Display .....	16
Verification by Visual Indication.....	18
Verification by Physical Measurement Main Bus Bars .....	19
Converter Assembly Bus Connections .....	20
Engine Cleaning.....	21
Tire and Rim Cleaning and Inspection.....	22
Glass Cleaning.....	23
Structural Component Cleaning and Inspection .....	23
Ladders, Handrails, Platforms, and Walkways .....	23
Structural Component and Weld Inspection after Cleaning .....	24
Radiator and Hydraulic Oil Cooler Cleaning.....	25
Areas Requiring Special Attention When Washing the Machine, To Avoid Component Damage .....	25
Electrical Converter Cabinet.....	25
Switches/Switchboxes/Enclosures with Internal Electrical Connections.....	27
Front and Rear Axle Vents .....	30
Solenoids and Cable Breakout Boxes .....	31
KLENZ™ Air Filtration System .....	31
Safety and Instructional Placards/Labels .....	32
Powered Access Ladder (Local Option for Some Models).....	33
Backup Alarm and Cowl Light Junction Box.....	33
Energy Storage Devices (ESDs) .....	34
Cleaning the Electrical Converter Cabinet and Axle Interior .....	35
Clearing Drain Holes in the Operator Cab Structure .....	36
After Washing the Machine.....	37

# Table of Figures

Figure 1.	Frame Lock.....	10
Figure 2.	Operators Screen – KESS at 60% .....	11
Figure 3.	ESD Motor Channel Select.....	12
Figure 4.	Drive Enable Switch.....	12
Figure 5.	ESD Motor RPM .....	12
Figure 6.	Open air reservoir bleed valves .....	14
Figure 7.	Converter assembly bus LED's .....	15
Figure 8.	LINCS logging/monitoring menu access .....	16
Figure 9.	Remove channels .....	16
Figure 10.	Left hand scroll .....	17
Figure 11.	Bus voltage indication.....	17
Figure 12.	Isolation and control switch assembly .....	18
Figure 13.	Bus voltage LED array on SR control board.....	18
Figure 14.	Main bus bars .....	19
Figure 15.	Converter assembly bus connections (rear of cabinet) .....	20
Figure 16.	Converter assembly bus connections (front of cabinet) .....	20
Figure 17.	Typical engine electronics package location .....	21
Figure 18.	Typical engine electronics package.....	21
Figure 19.	Typical engine starter location .....	21
Figure 20.	Typical engine alternator location .....	21
Figure 21.	Typical engine interface box and typical locations .....	22
Figure 22.	Windshield washer reservoir (optional) .....	23
Figure 23.	Rear frame (typical) .....	25
Figure 24.	Radiator (typical).....	25
Figure 25.	Electrical converter cabinet (typical).....	25
Figure 26.	Electrical Converter Cabinet door seal (typical) and floor vent .....	26
Figure 27.	Converter panel seal (typical).....	26
Figure 28.	Emergency stop switch typical locations .....	27
Figure 29.	Air Box location (typical) .....	28
Figure 30.	Engine air restriction indicators box.....	28
Figure 31.	Low voltage control cabinet location.....	28
Figure 32.	Isolation and control switch box and engine interface box typical locations .....	29
Figure 33.	Component heater connection box.....	29
Figure 34.	Typical axle vent front frame.....	30
Figure 35.	Typical axle vent .....	30
Figure 36.	Typical axle vent rear frame .....	30
Figure 37.	Typical solenoid location.....	31
Figure 38.	Typical breakout box.....	31
Figure 39.	Typical KLENZ™ air intake area .....	31
Figure 40.	Typical KLENZ™ filters.....	31
Figure 41.	Typical KLENZ™ air intake area .....	32
Figure 42.	Typical KLENZ™ filters.....	32
Figure 43.	Typical powered ladder control boxes .....	33
Figure 44.	Typical cowl/radiator area.....	33
Figure 45.	Typical ESD .....	34
Figure 46.	Typical ESD air vent location.....	34
Figure 47.	Shock hazards .....	35
Figure 48.	Typical drain holes in cab structure .....	36

# Scope of This Publication

This document provides general procedures/processes used when cleaning Komatsu equipment. Some photographs show various machine models and may illustrate equipment not present on all machine models.

All local procedures and all appropriate rules and regulations shall be used when cleaning machines. Follow all appropriate lawful procedures/rules/regulations (not covered in this document) to contain and, dispose of chemicals. Contact the manufacturer for MSDS sheets for chemicals. Always contain all chemicals as applicable.

## Safety

This publication contains special instructions that pertain to safety, operation, maintenance, and repair of the machine. Listed below are the signal words and symbols that precede these instructions and their meanings:

### DANGER

- The danger label indicates a hazardous situation which, if not avoided, will result in death or serious injury.

### WARNING

- The warning label indicates a hazardous situation which, if not avoided, could result in death or serious injury.

### CAUTION

- The caution label, used with the safety alert symbol indicates a hazardous situation which, if not avoided, could result in minor or moderate injury (includes the safety alert symbol .

### CAUTION

- The caution label (without safety alert symbol) is used to address practices not related to personal injury – only equipment damage.

### NOTICE

The NOTICE graphic is to indicate areas of importance to the reader that are not related to personal injury or machine damage.

## Safety, Warnings and Cautions

### WARNING

#### FIRE OR ELECTRICAL HAZARD

- Fire or electrical hazards exist when there is a buildup of combustible dust in any electrical compartment. It is critically important to remove any accumulation of combustible or conductive material as part of the electrical system preventive maintenance program and the cleaning program. Failure to remove accumulation of combustible or conductive material can result in fire or electrical hazard resulting in serious injury or death.

#### CRUSH HAZARD

- Crush hazards exist if the machine is started or moved while work processes are being performed on the machine. Place bucket flat and level on the ground. Place frame lock in the locked position and lock out the machine's starting capability before performing any work process. Follow all applicable lockout procedures and local rules and regulations for performing work processes. ANYONE performing inspections or service procedures to the machine should be familiar with ALL instructions and procedures contained in the machine's SERVICE MANUAL. Crush hazard could occur if the machine is started or moves while any type of work process is being conducted on the machine, resulting in serious injury or death.
- Crush hazards exist in machine pivot area and area between the tires. Do not enter these areas unless it is verified that the operator has control over the steering and that personnel locking the frame lock have good communication with the operator. Entering the pivot area and area between the tires while the machine is moving or pivoting (articulating) could cause crush hazards resulting in serious injury or death.
- Crush hazards exist if all personnel are not cleared from the bucket and lift arm area before using the hydraulic hoist and bucket hydraulic pressure bleed down valves to relieve pressure from the hoist and bucket circuit. Clear all personnel from the area around the bucket and lift arms before operating hydraulic hoist and bucket hydraulic pressure bleed down valves. Using the hydraulic bleed down valves could result in some movement of the lift arms and bucket which could cause a crush hazard resulting serious injury or death.

#### CRUSH, SHOCK, OR OTHER HAZARDS

- Crush, shock, or other hazards exist if stored energy is not removed or isolated prior to working on the machine. Stored energy (hydraulic, electrical, pneumatic, mechanical, etc.) may be present if not isolated or released prior to working on the machine. Do not work on the machine without removing this stored energy (suspended loads, electrical power, air pressure, etc.). Risk of crushing, shock, or other physical injury exists if stored energy is not removed or isolated prior to working on the machine which could result in serious injury or death.

#### ELECTRICAL SHOCK HAZARD

- Risk of fatal electrical shock or injury by contact in the electrical cabinet is possible if the engine is running, the LINCOS software indicates voltage on the bus, or the red bus LED's in the electrical cabinet are illuminated. All Generation II SR equipment has the ability to produce voltage at low throttle. Even with the engine off, there may be a residual of 12-15VDC on the bus. Do not enter the electrical cabinet or touch any components in the electrical cabinet without performing the Bus Discharge Verification Procedure. Failure to do so may result in fatal electrical shock or other injury.
- High voltage may be present. Risk of shock or equipment damage by use of an improperly rated meter is possible. Use a CAT III 1000V rated volt meter to take voltage readings.

- **Electrical shock hazard exists if inspection or service procedures involve contact with any component of the electrical system, opening the electrical converter cabinet or removing axle access covers. NEVER remove axle access panels unless electrical system is locked out. Do not touch electrical components unless the electrical system is locked out. Always verify the absence of bus voltage before removing axle access panels or entering the electrical converter cabinet. NEVER open the Electrical Converter Cabinet while the engine is running. High voltage is present when machine is at high throttle, and can be present at low throttle or up to five minutes after the machine engine is shut down. Accidental contact with energized terminals could cause an electrical shock resulting in serious injury or death.**

 **CAUTION****PERSONAL PROTECTIVE EQUIPMENT**

- **Burn hazard exists when using a steam cleaner or high-pressure washer to clean the machine or components. Burns from steam or hot water are possible. Use personal protective equipment, protective clothing, and safety glasses or a face shield. Use caution to prevent contact with steam. Using a high-pressure steam washer can cause a burn hazard resulting in serious personal injury.**

This Page Intentionally Left Blank

# Theory of Operation

Regular cleaning of the machine will, over time, save repair costs, reduce labor time, and reduce fuel costs, plus enhance company image, employee morale, and safety.

Komatsu diesel-electric powered loaders and dozers require specific cleaning procedures to avoid damage to sensitive electronic components, the air filtration system, and the engine.

These general instructions include recommendations for areas that require cleaning as part of proper maintenance and areas that require special attention to avoid damage to the machine. Cleaning the machine for inspection of load bearing members and mainframe welds is a critical part of a comprehensive preventive maintenance program.

Typical machines are used for illustrative purposes in the following information.

## Component Description

### Recommended Washing Equipment – Hot Water High-Pressure Washer or Steam Cleaner

Hot water high-pressure washers and steam cleaners quickly and efficiently remove buildups of dirt, grease, and other contaminants from machine components.

- Various spray nozzles provide different patterns for specific cleaning applications. A 0° nozzle provides a solid, forceful stream of high-pressure water. When it is necessary to blast loose tough accumulations of dirt and grime, a 0° nozzle is the most effective. A broader range (up to 40°) is most advantageous for cleaning large, flat surfaces.
- Hold the cleaning wand 6 to 12 inches from the surface for best results.
- A trigger shutoff on the pistol grip of the cleaning gun allows for fast water shutoff, thus saving water and energy.

### CAUTION

**Burn hazard exists when using a steam cleaner or high-pressure washer to clean the machine or components. Burns from steam or hot water are possible. Use personal protective equipment, protective clothing, and safety glasses or a face shield. Use caution to prevent contact with steam. Using a high-pressure steam washer can cause a burn hazard resulting in serious personal injury.**

## Additional Recommended Equipment

- Wash bay – with concrete floor where water, dirt, and grease can be properly drained to ensure environmental hazards are not created.
- Wheel chocks
- Lock and key for the Lockout Tagout procedure
- Tall ladder
- All necessary safety equipment, such as:
  - Protective clothing
  - Safety glasses or a face shield
  - Breathing protection

# Procedures/Processes

## CAUTION

Regular cleaning of all areas where flammable materials such as fuel, oil, grease, hydraulic fluid, and combustible debris may collect is critically important.

- The machine should be thoroughly cleaned after any fluid leak.
- Areas that should be cleaned regularly include (but are not limited to):
  - Inside front frame
  - Rear frame underneath and on sides of engine
  - Top of engine, rear frame under the Hydraulic Pump Drive (HPD) gearbox and top of HPD
  - Rear frame under stairways, cabinets
  - Underneath cab, inside cab
  - Around engine radiator area
  - Any area where a buildup of materials could pose a fire hazard.
- Cleaning is also required in order to do the frame inspection.

Failure to properly clean, and keep the machine clean could result in destructive fire.

## Safety Preparations

Use the following process and local rules, requirements, and regulations to remove stored energy and to reduce the possibility of crush hazards before performing any work process on or around the machine.

## WARNING

Crush hazards exist if the machine is started or moved while work processes are being performed on the machine. Place bucket flat and level on the ground. Place frame lock in the locked position and lock out the machine's starting capability before performing any work process. Follow all applicable lockout procedures and local rules and regulations for performing work processes. Crush hazard could occur if the machine is started or moves while any type of work process is being conducted on the machine, resulting in serious injury or death.

## WARNING

Crush hazard exists if the frame lock is not locked to prevent machine articulation while personnel are in the machine articulation area. Do not enter this area unless you have verified that the operator has control over the steering and that you have good communication with the operator. Crush hazard is possible if personnel are in this area while the machine is articulated, which could result in serious injury or death.

## ⚠️ WARNING



Shock hazard exists on the components of the KESS system. Perform the KESS discharge procedure to remove stored energy from the KESS system and bring the ESD to a stop. Once the ESD has stopped, perform the Bus Discharge Verification Procedure. Failure to do so may result in electrical shock or other injury.

## ⚠️ WARNING

Crush hazards are possible if the machine is started or moved while work processes are being performed on the machine. Place bucket flat and level on the ground. Place frame lock in the locked position and lock out the machine's starting capability before performing any work process. Follow all applicable lockout procedures and local rules and regulations for performing work processes. Serious personal injury or death could occur if the machine is started or moves while any type of work process is being conducted on the machine.

- a. Stop the wheel loader on flat level ground.
- b. Set bucket flat and level on the ground.
  - Ensure there is no material in the bucket.
- c. Move the frame lock to the locked position so that the frame cannot be steered.

## ⚠️ WARNING

Crush hazard is possible if the frame lock is not locked to prevent machine articulation while personnel are in the machine articulation area. Do not enter this area unless you have verified that the operator has control over the steering and that you have good communication with the operator. Crush hazard is possible if personnel are in this area while the machine is articulated, which could result in serious injury or death.

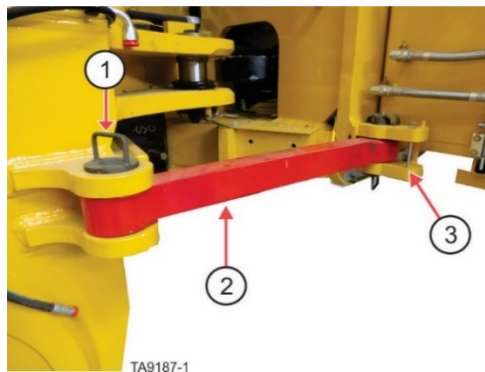

- 1) Retaining pin for locked position, 2) Frame lock – shown in locked position,
- 3) Retaining pin bracket for un-locked position

**Shown in locked position**

**Figure 1. Frame Lock**

- d. Place wheel chocks in front and behind each wheel.
  - Chocking against motion must be done using chocks rated for the equipment being chocked. Heavy mobile equipment must be chocked with appropriate chocks. Factors such as machine weight, size, wheel diameter, ground grade and others must be considered when selecting chocks

- e. Set the parking brakes.

The KESS (Kinetic Energy Storage System) is composed of one or more ESD's (Energy Storage Device), converter panels, and fuses, controlled by the Vehicle Control Unit (VCU).

The ESD operates in a range of 1,600 to 6,000 RPM when the machine is at high throttle and the park brake is released. If the KESS is not discharged, the ESD can continue to rotate for two hours once the machine has been shut down.

Before performing any work procedures on the KESS system, verify the ESD is not rotating. Verification can be accomplished by using the LINC'S II software to view the ESD RPM.

The purpose of the KESS discharge procedure is to dissipate potential energy so that the KESS system components may be serviced or repaired. If for any reason, the KESS cannot be discharged, service on the machine must be delayed for two hours, giving the ESD time to come to a complete stop.

Discharging the KESS should be done before shutting the machine down by performing the following steps:



**Figure 2. Operators Screen – KESS at 60%**

- f. Ensure Park Brake is SET
- g. Place machine at LO Throttle
- h. Select Main Menu button
- i. Select Data Logging
- j. Select Logging/Monitoring
- k. Select Energy Storage Data Link
- l. Move ESD 1 Mst:Motor (RPM) and ESD 2 Mst:Motor (RPM) to right column by clicking and dragging



Figure 3. ESD Motor Channel Select

m. Press the Drive Enable Switch



Figure 4. Drive Enable Switch

n. The ESD Mst:Motor RPM will start to decline and will reach 0 RPM in approximately 35 seconds.



Figure 5. ESD Motor RPM

## ⚠ WARNING

Crush, shock, or other hazards exist if stored energy is not removed or isolated prior to working on the machine. Stored energy (hydraulic, electrical, pneumatic, mechanical, etc.) may be present if not isolated or released prior to working on the machine. Do not work on the machine without removing this stored energy (suspended loads, electrical power, air pressure, etc.). Risk of crushing, shock, or other physical injury exists if stored energy is not removed or isolated prior to working on the machine which could result in serious injury or death.

- o. Shut off the engine.
- p. Turn the battery and engine isolation switches to the off position and install locks on the battery isolation switch. Lock out the machine's starting capability before performing any cleaning, inspections, or installation and repair procedure.



**Isolation and Control switches assembly – Battery isolation switch in OFF position with locks in place**

- q. Release the air from the hydraulic reservoir by using the hydraulic reservoir air valve (ball valve) on top of the reservoir. The supply line from main air system will be blocked and reservoir air will vent out the hose that runs down the outside of the hydraulic reservoir.
- r. Turn the handle to the up position as shown.

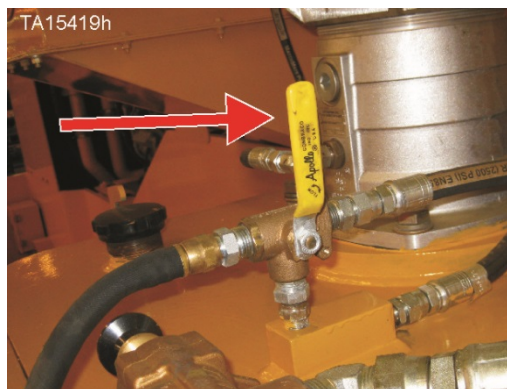

**Hydraulic reservoir air valve handle UP**

- s. Release the air from the various air storage reservoirs by opening all of the air bleed valves.

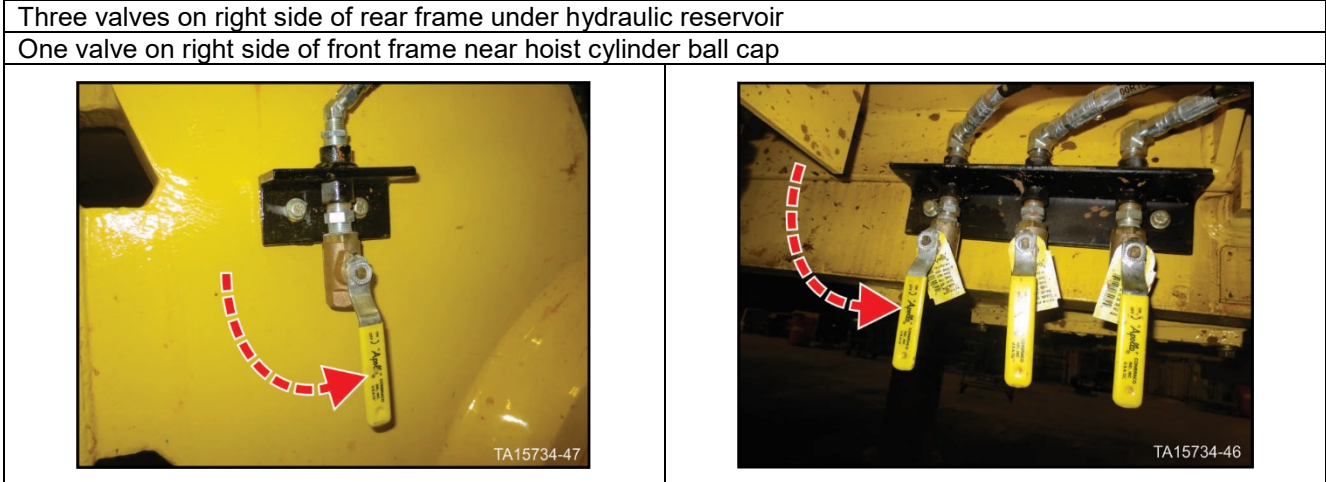
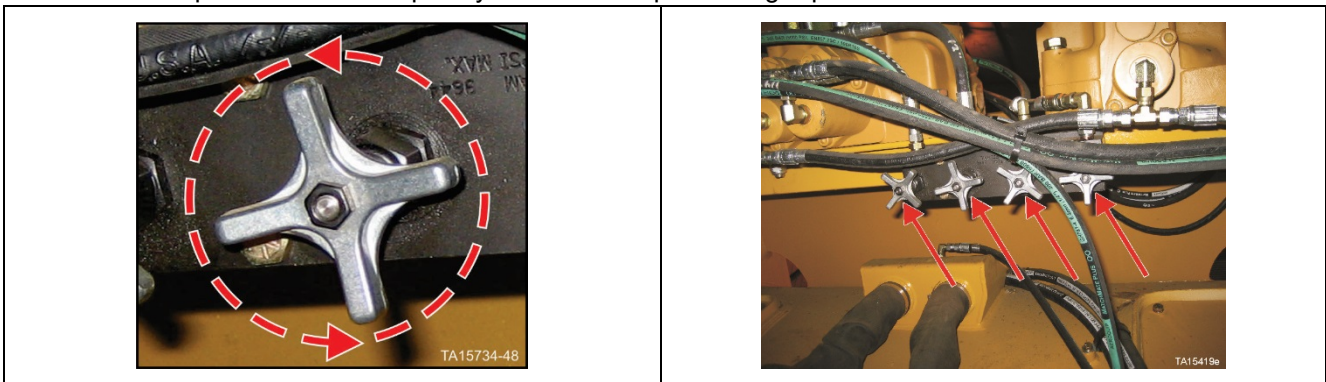

Figure 6. Open air reservoir bleed valves

**⚠ WARNING**

Crush hazard exists by the lift arms or bucket if all personnel are not cleared from the bucket and lift arm area before using the hydraulic hoist and bucket pilot pressure bleed down valves to relieve pressure from the hoist and bucket pilot circuit. Clear all personnel from the area around the bucket and lift arms before operating hydraulic hoist and bucket pilot pressure bleed down valves. Using the hydraulic bleed down valves could result in some movement of the lift arms and bucket which could cause injury or death.

- t. Use the hydraulic pressure bleed down valves located in the front frame underneath the Husco valves to bleed any stored pressure in the hoist and bucket circuit.
  - o Turn each valve slowly counterclockwise as shown below and allow the pressure to bleed down.
  - o Open the valve completely and leave it open during repairs.



- u. Drain the hydraulic reservoir if applicable to the procedure being performed.

## Converter Bus Voltage

### **WARNING**



Risk of fatal shock or injury by contact in the electrical cabinet is possible if the engine is running, the LINCOS software indicates voltage on the bus, or the red bus LED's in the electrical cabinet are illuminated. All SR equipment has the ability to produce voltage at low throttle. Even with the engine off, there may be a residual of 12-15VDC on the bus. Do not enter the electrical cabinet or touch any components in the electrical cabinet without performing the Bus Discharge Verification Procedure. Failure to do so may result in fatal electrical shock or other injury.

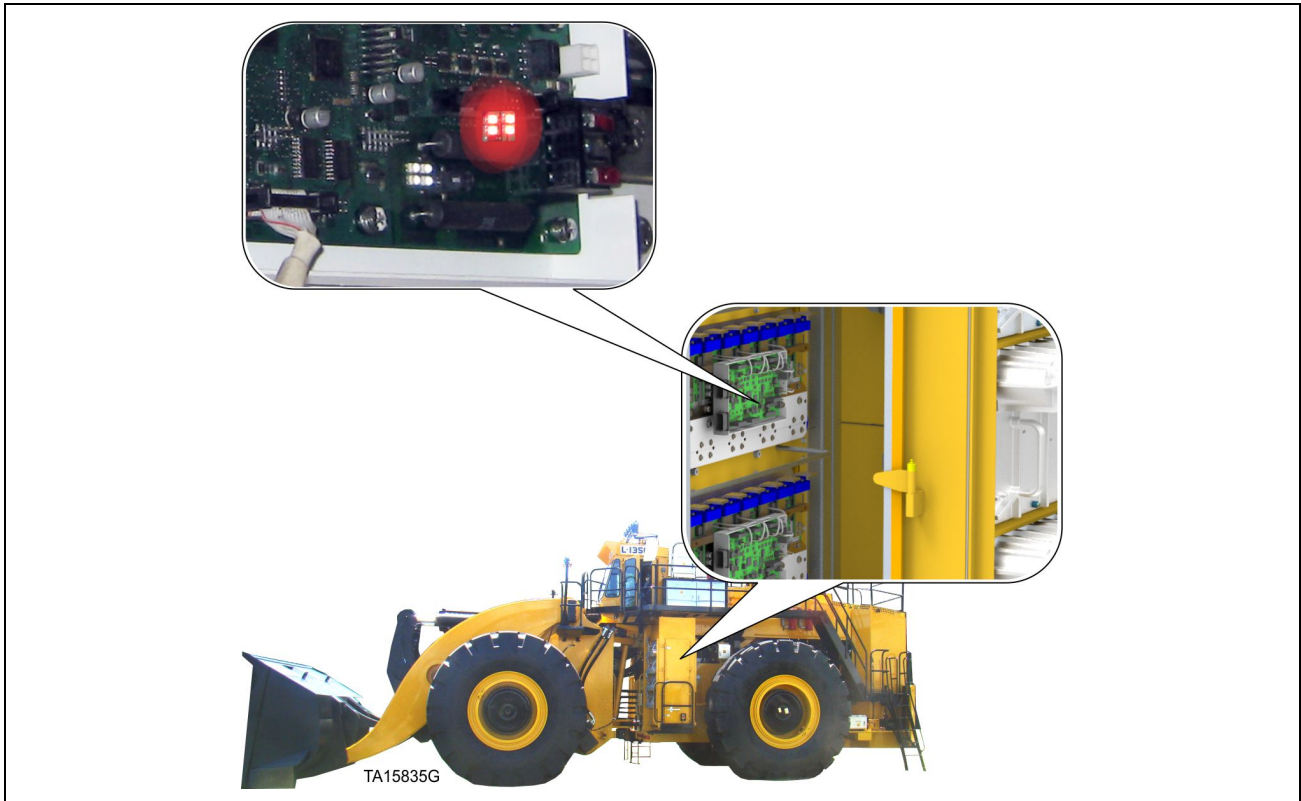

**Figure 7. Converter assembly bus LED's**

There are three different methods that are combined to verify when it is safe to enter the electrical cabinet.

LINCOS II display in cab

visual indication in electrical cabinet

physical measurement

All of these steps are required in order to assure that the system is properly discharged.

### In Cab Verification Using LINCS II Display

- a. Make sure that the LINCS II system is booted (key switch ON) with the engine NOT running and the park brake SET.
- b. As shown in the following figure, on the touch panel in the dash, press the Main Menu button in the lower left corner, then select Data Logging then Logging/Monitoring.



**Figure 8. LINCS logging/monitoring menu access**

- c. Select the Trash Can icon and then select the Check Mark to clear any selection on the right hand side of the screen (if applicable).

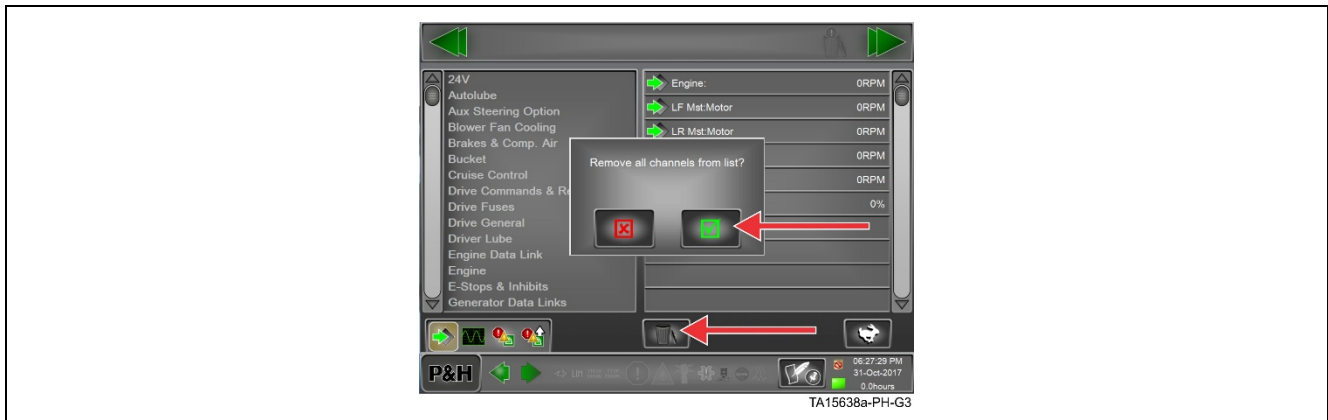

**Figure 9. Remove channels**

d. Scroll down the left hand list until Drive Fuses is displayed.



Figure 10. Left hand scroll

e. Drag the Drive Fuses category to the right hand side of the screen, all of the bus voltage channels should now be visible.



Figure 11. Bus voltage indication

f. Verify bus voltage is less than 24VDC.

## NOTICE

**Should any voltage (greater than 24VDC) be present on any of the DC busses, allow the system to discharge for a period of no less than 10 minutes. Re-test the bus voltages prior to continuing.**

g. Turn the key switch to the OFF position and proceed to the next step in the verification process.

## Verification by Visual Indication

Following the verification by LINC'S II software, the next step is to verify the existence of bus voltage by the array of four LED indicators located on the main SR control board on each converter assembly.

To conduct this test, ensure that:

- The 24V DC power is isolated at the battery disconnect (turned off and locked out) per site requirements.

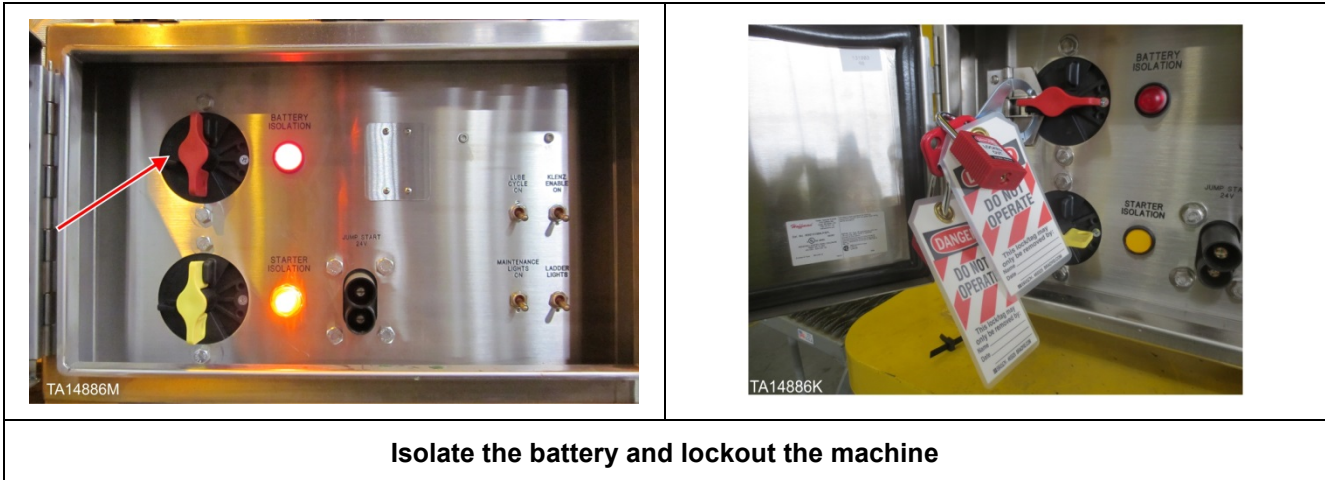

**Isolate the battery and lockout the machine**

**Figure 12. Isolation and control switch assembly**

- The SR electrical converter cabinet door should now be opened.
- DO NOT enter the cabinet at this time.

View the LED arrays on each of the converter assemblies and verify the LED's are not illuminated. The LED's will be illuminated when a potential of greater than approximately 35VDC is present on the DC bus connections on the converter assemblies. The light intensity varies with voltage and a greater intensity indicates a higher bus voltage.

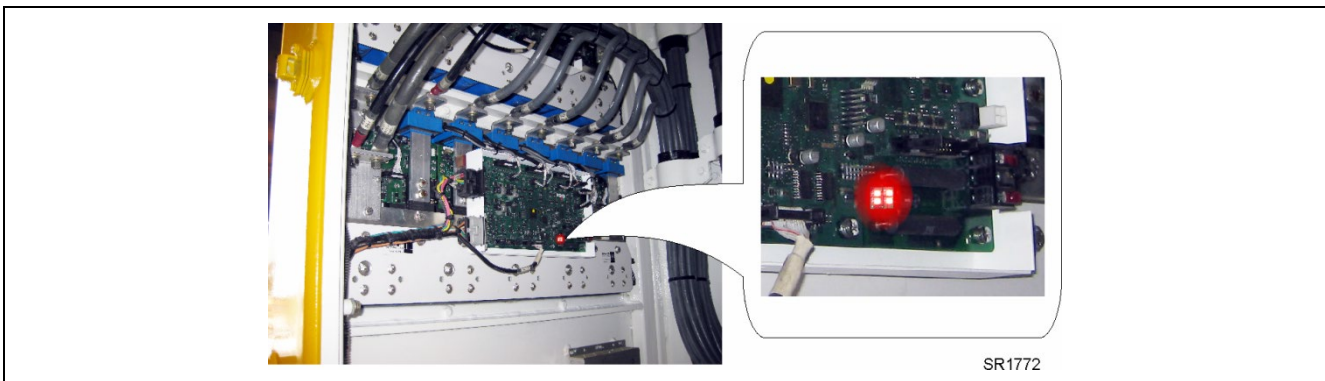

**Figure 13. Bus voltage LED array on SR control board**

Once verified that the LED's are NOT illuminated, proceed with Verification by Physical Measurement of the main bus bars.

## Verification by Physical Measurement Main Bus Bars

Once the visual indicators have been verified, the bus voltage should be physically measured. The bus voltage should be fully discharged based on the previous checks.

- a. Measure between the positive and negative bus bars using a voltmeter rated for 1000V. The potential voltage on a bus that has not discharged could be over 700VDC. A properly discharged bus should be less than 24VDC as verified by the completion of LINCS system verification.

### **WARNING**

Risk of shock or equipment damage by use of an improperly rated meter is possible. Use a CAT III 1000V rated volt meter to take voltage readings. Shock or other injury may result from using improperly rated test equipment.

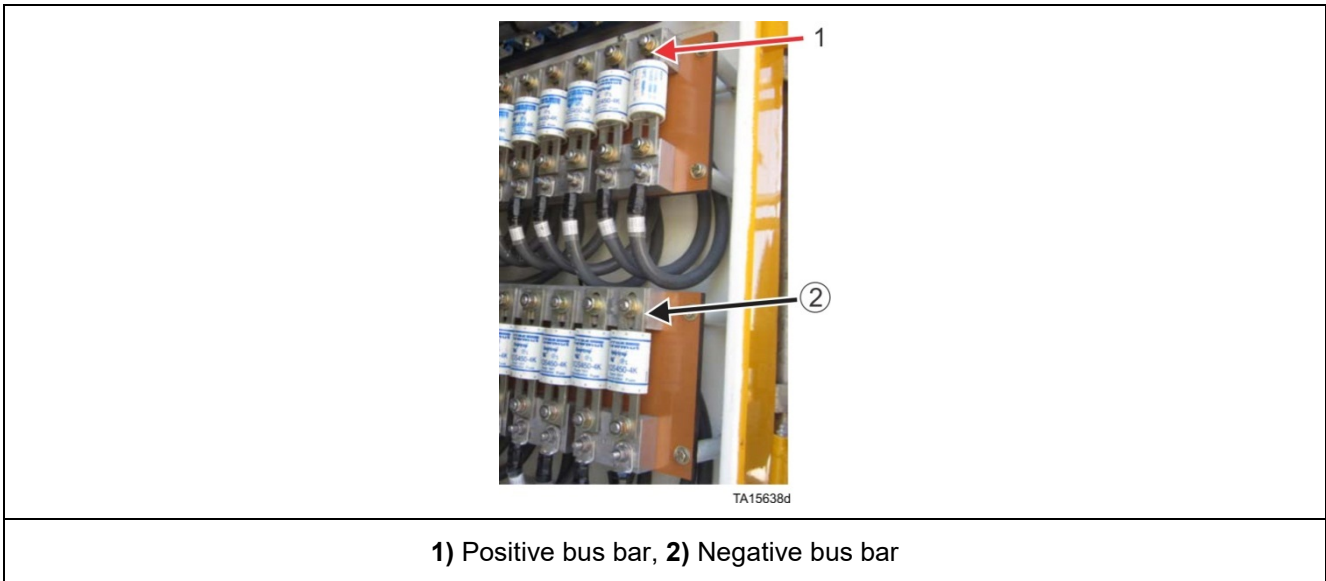

**Figure 14. Main bus bars**

## Converter Assembly Bus Connections

The final point of verification is the bus connections to each individual converter assembly. The bus voltage can be measured at the two bus tabs located adjacent to the electrical converter cabinet door.

### NOTICE

**The converter assemblies on the rear of the cabinet are inverted in comparison to those mounted on the front. Similarly, the positive and negative bus connections will be inverted.**

Connect a voltmeter across the two bus connection points. Bus voltage should be less than 24VDC following the completion of the previous checks. Once the check has been completed, the entire drive system has been verified as discharged.



1) Positive bus bar, 2) Negative bus bar

**Figure 15. Converter assembly bus connections (rear of cabinet)**

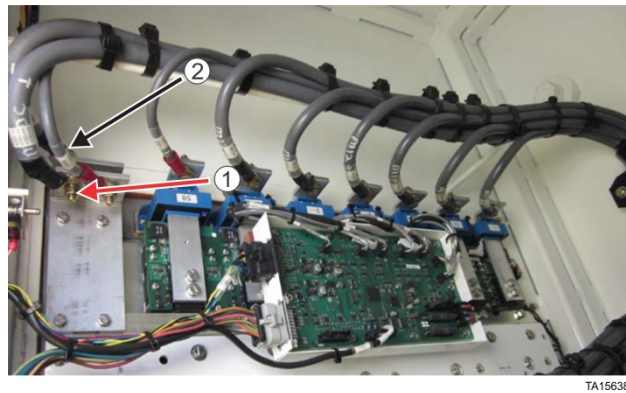

1) Positive bus bar, 2) Negative bus bar

**Figure 16. Converter assembly bus connections (front of cabinet)**

Once verified that bus voltage does not exist, entry into the electrical cabinet, axels, and grid area are permissible.

# Engine Cleaning

The engine should be steam cleaned **ANNUALLY** or more often during extreme conditions. Steam is the best method for cleaning a dirty engine. If a steam cleaner is not available, use a solvent with a hot water high-pressure washer to clean the engine. Look for fuel, oil, and coolant leaks that may not be visible on a dirty engine. **Left unattended, these leaks can be a fire hazard.**

The engine electronics packages are located in various places on different models. Care must be taken when washing around the engine electronics.

## CAUTION

**DO NOT spray the engine electronics with the full force of the steam cleaner or hot water high-pressure washer. Equipment damage can occur.**

Use caution when washing around the starter(s) and alternator. **DO NOT spray these components with the full force of the steam cleaner or hot water high-pressure washer.**

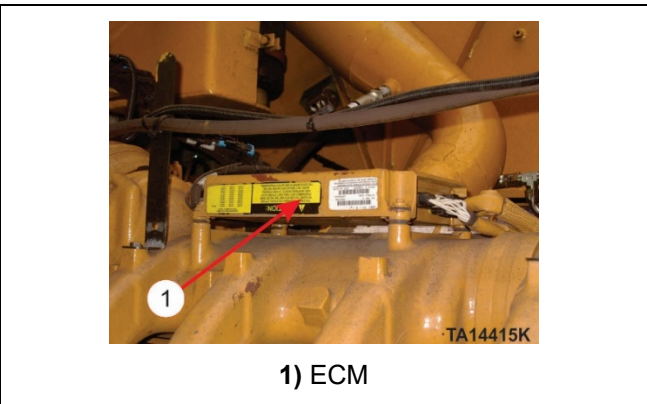
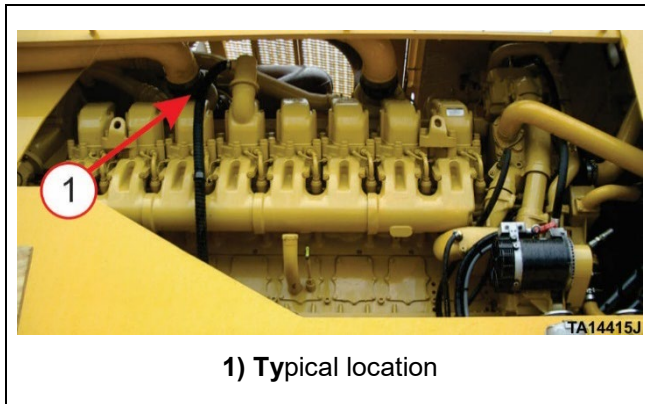

Figure 17. Typical engine electronics package location

Figure 18. Typical engine electronics package location

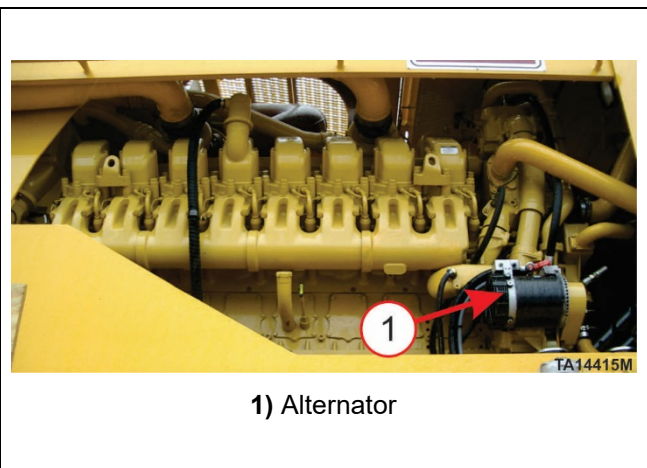
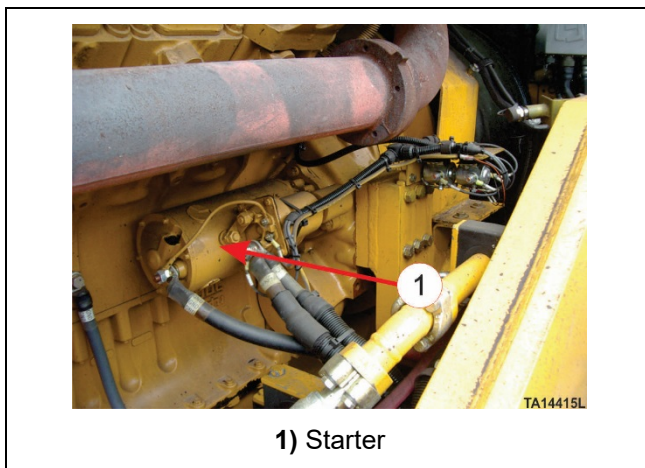

Figure 19. Typical engine starter location

Figure 20. Typical engine alternator location

DO NOT spray the Engine Interface box seals with the full force of the steam cleaner or hot water high-pressure washer. Water could enter the box and cause damage to the internal electronics.



Engine interface box



Figure 21. Typical engine interface box and typical locations

## Tire and Rim Cleaning and Inspection

**Tires need to be dirt and grease free to enhance life.** The tires should be included in any washing procedures with particular attention shown for removing oil and grease.

**Often, tire damage is hidden under dirt or mud. Tires should be inspected thoroughly after they are washed.** All tires should be inspected for cuts, bruises, fabric breaks, excessive or uneven wear, embedded stones, and any other damage that can be repaired. A considerable increase in tire service can be achieved if tire damage is repaired before it has progressed to the non-repairable stage. Refer to Section 3 in the Service Manual, for more information about "TIRES & RIM".

**Rims that are caked with dirt and mud can add unnecessary weight to a machine and adversely affect its performance.** Inspect the rims both inside and outside. Any accumulations of dirt and mud should be washed away. Closely inspect rim parts and attaching nuts and bolts that may be bent, rusted, loose, or missing and repair or replace them immediately.

## Glass Cleaning

The glass in the operator's cab should be kept clean on the inside and outside. Dirt, soot, grease, ice, and snow can smear and streak and adversely affect the operator's view of the load, trucks, other vehicles, and hand signals. The wiper blades should be routinely inspected and replaced at least once a year or as needed. The reservoir for the windshield washers is mounted on the rear of the operator's cab. The reservoir has a capacity of five gallons (19 liters). Use commercially available windshield washer solvent mixed in a consistency to prevent freezing.

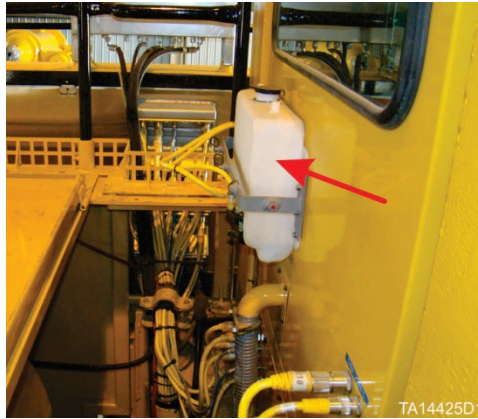

(Mounted on right rear of operators cab)

Figure 22. Windshield washer reservoir (optional)

## Structural Component Cleaning and Inspection

Every 1000 hours the entire machine should be cleaned with a hot water, high-pressure washer, or steam cleaner to facilitate a thorough inspection of the weld joints and plates for cracks or breaks.

## Ladders, Handrails, Platforms, and Walkways

The ladders, handrails, platforms, and walkways on the machine should be thoroughly cleaned. They should be kept free of dirt, mud, debris, grease, oil, ice, and any other materials that could cause personnel to slip or fall when mounting or dismounting the machine.

Any ladders, handrails, platforms, or walkways that are bent should be straightened.

## Structural Component and Weld Inspection after Cleaning

After a thorough cleaning of the machine, all welds and load bearing and ground contact components should be closely inspected for cracks. Special attention should be paid to the ends of welds, corners, and bends. Particular attention should be paid to load bearing attachments such as loader buckets, arms, and ball joints. The entire assembly and the mounting locations should be thoroughly inspected. Refer to "INSTRUCTIONS FOR 1000 HOUR STRUCTURAL AND WELD INSPECTION REPORT" located in Section 02 "MODULAR PM SCHEDULES". Use of this report will provide a systematic method of inspection and enable inspection data to be accurately transmitted to Komatsu Authorized Distributors and the Komatsu Product Support Group.

### NOTICE

**A dye penetrate test should be done on any welds that are suspected of being cracked. Refer to Section 03 "FIELD WELDING PROCEDURES" for instructions regarding the welding of Komatsu structural steel. Also, contact your authorized Komatsu distributor for assistance before welding on any load-bearing components of the loader.**

### CAUTION

**To prevent damage to the Detroit or Cummins electronic control system, disconnect the following BEFORE welding: battery power, ground cables, and the power connector at the Detroit or Cummins engine electronics. Failure to isolate the engine electronics system from high current possible occurrence as a result of welding) can result in severe electronics damage. Typical examples of engine electronics are DDEC, ADEC, and ECM.**

All bolts, nuts, and fasteners should be inspected to identify any that are broken, loose, or missing. Any such bolts should be replaced immediately with equivalent grade bolts. Refer to Section 01 in the Service Manual for more information on the "CAPSCREW TORQUE CHART".

## Radiator and Hydraulic Oil Cooler Cleaning

When washing the radiator and hydraulic oil cooler, first swing the radiator guard open, then swing the braking grids out of the way. This will provide full access to the radiator and hydraulic oil cooler. **DO NOT wash the braking grids with high-pressure hot water or steam. They should be washed gently to prevent component damage.**

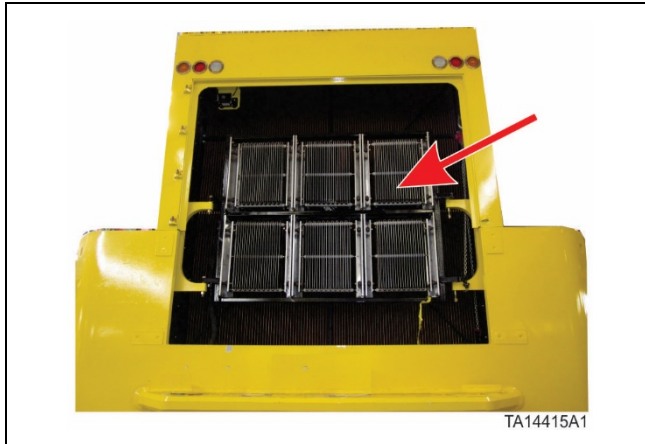

Figure 23. Rear frame (typical)



Braking grid might vary in appearance.

Figure 24. Radiator (typical)

## Areas Requiring Special Attention When Washing the Machine, To Avoid Component Damage

### Electrical Converter Cabinet



Figure 25. Electrical converter cabinet (typical)

## CAUTION

**DO NOT** direct the full force of a hot water high-pressure washer or steam cleaner at the door seals of the Electrical Converter Cabinet (or any electrical enclosures). It is possible to force water past the seals.

## CAUTION

**DO NOT** direct the full force of a hot water high-pressure washer or steam cleaner at the bottom (under side) of the Electrical Converter Cabinet, for a prolonged time. It is possible to force water into

the cabinet, because the bottom has a perforated panel for air flow. Check the panel airflow openings to ensure they are clear.

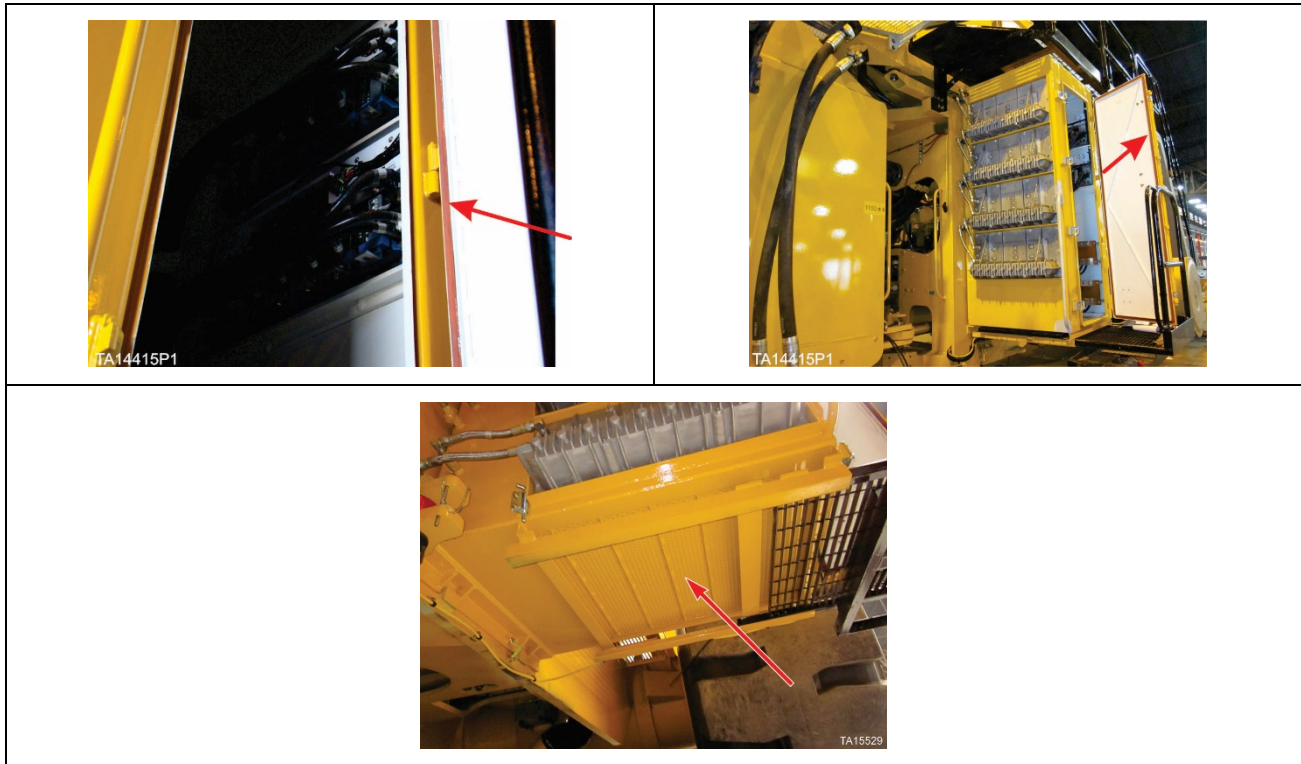
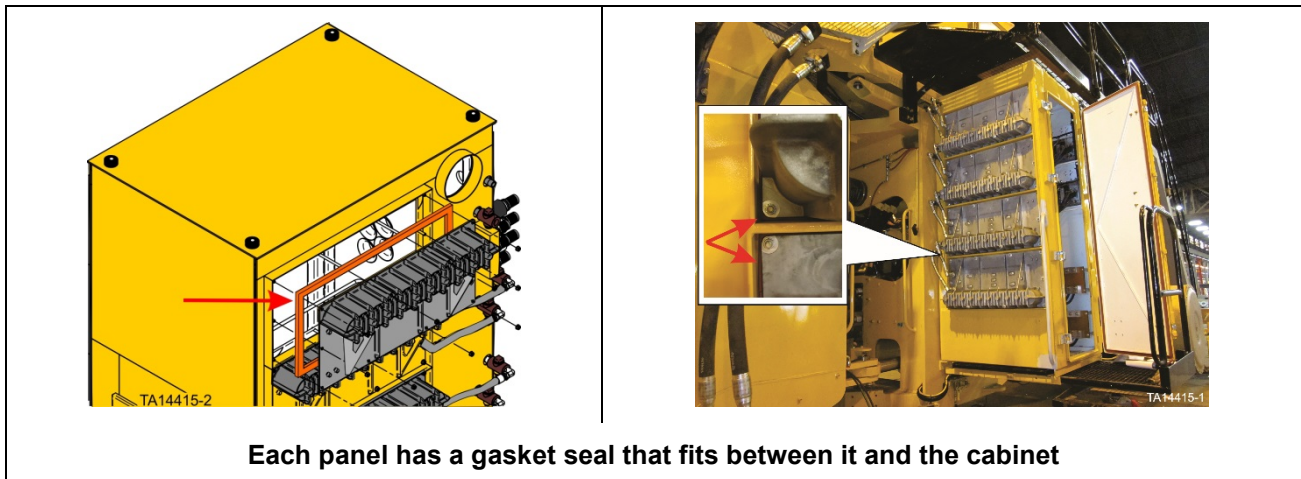

Figure 26. Electrical Converter Cabinet door seal (typical) and floor vent

## CAUTION

DO NOT direct the full force of a hot water high-pressure washer or steam cleaner at the seals of the converter panels. It is possible to force water past the seals and into the cabinet.



Each panel has a gasket seal that fits between it and the cabinet

Figure 27. Converter panel seal (typical)

### Switches/Switchboxes/Enclosures with Internal Electrical Connections

DO NOT direct the full force of a hot water high-pressure washer or steam cleaner at the exterior mounted switches, or switch box seals mounted on both sides of the machine.

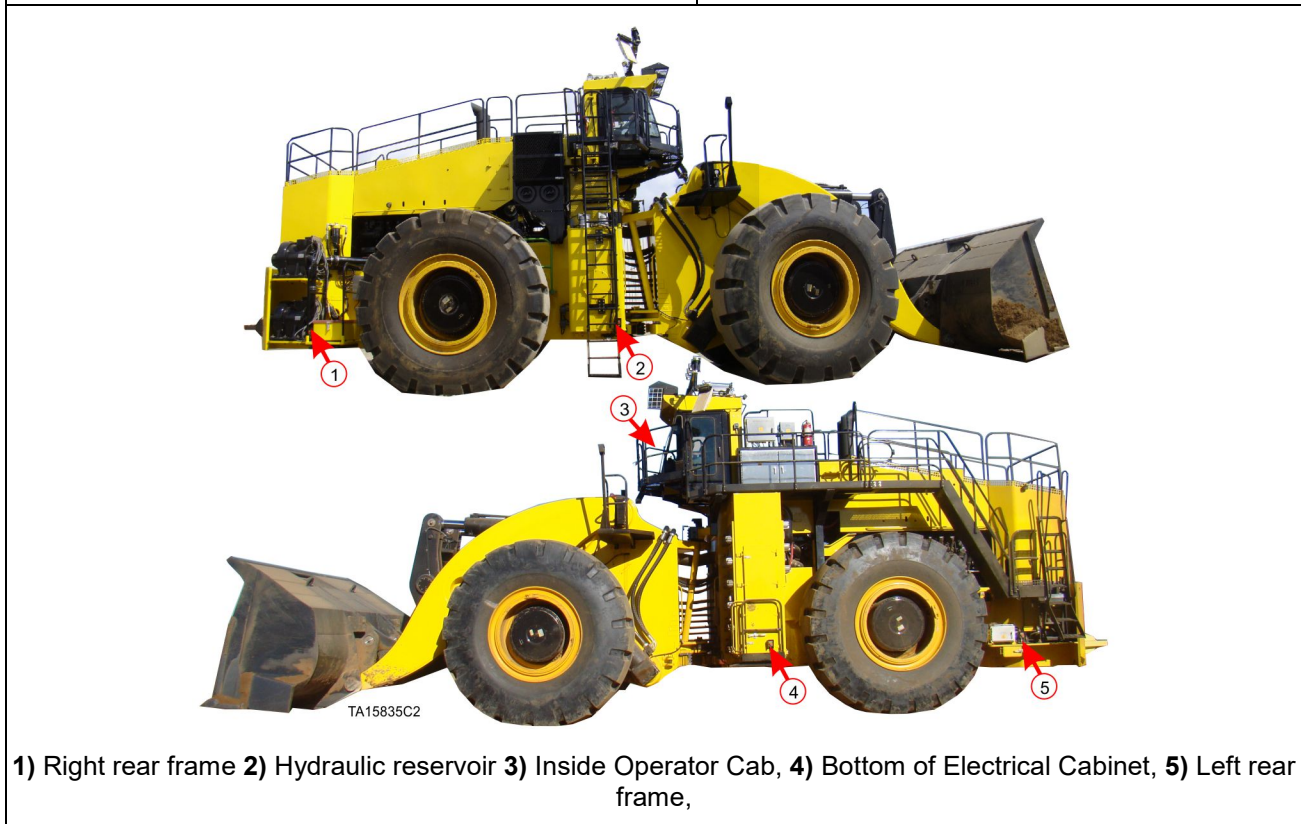
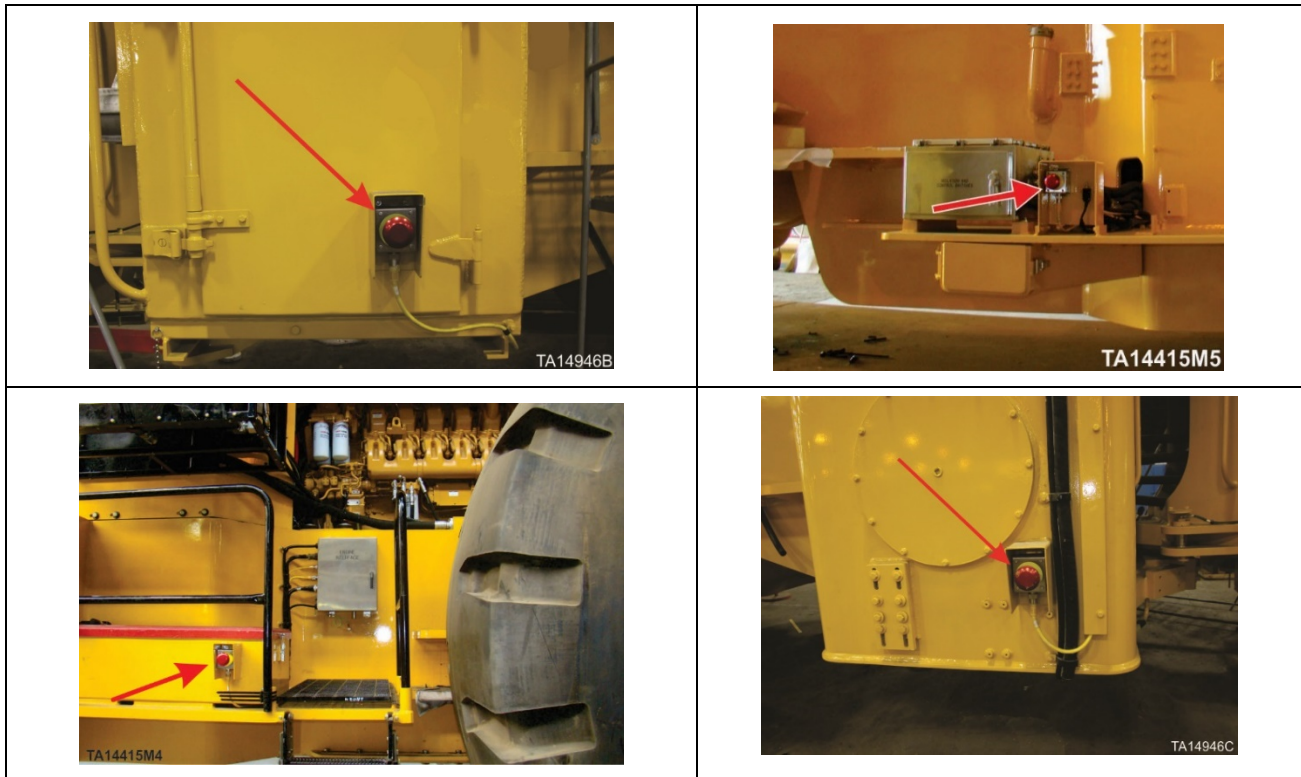

1) Right rear frame 2) Hydraulic reservoir 3) Inside Operator Cab, 4) Bottom of Electrical Cabinet, 5) Left rear frame,

**Figure 28. Emergency stop switch typical locations**



Figure 29. Air Box location (typical)



Figure 30. Engine air restriction indicators box

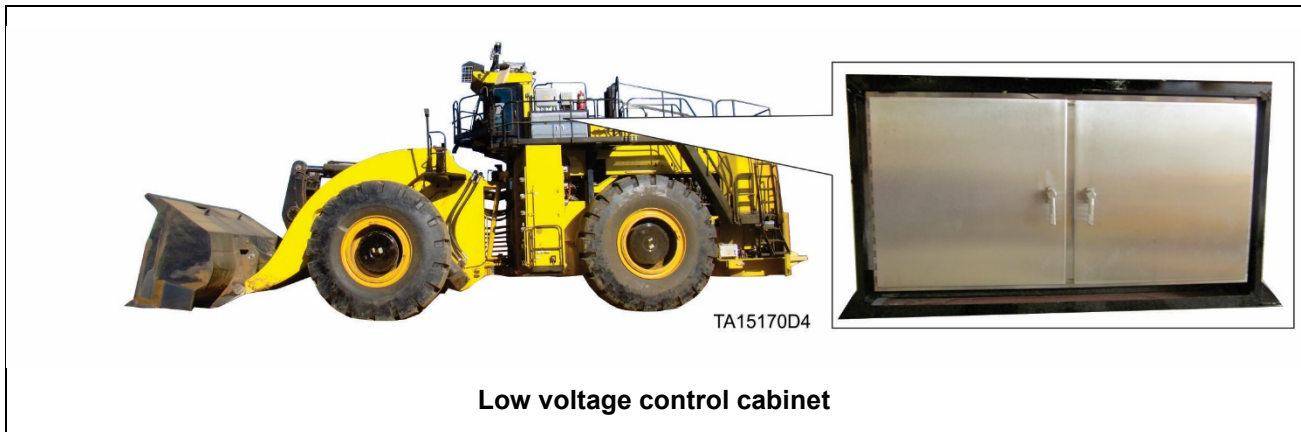

Low voltage control cabinet

Figure 31. Low voltage control cabinet location

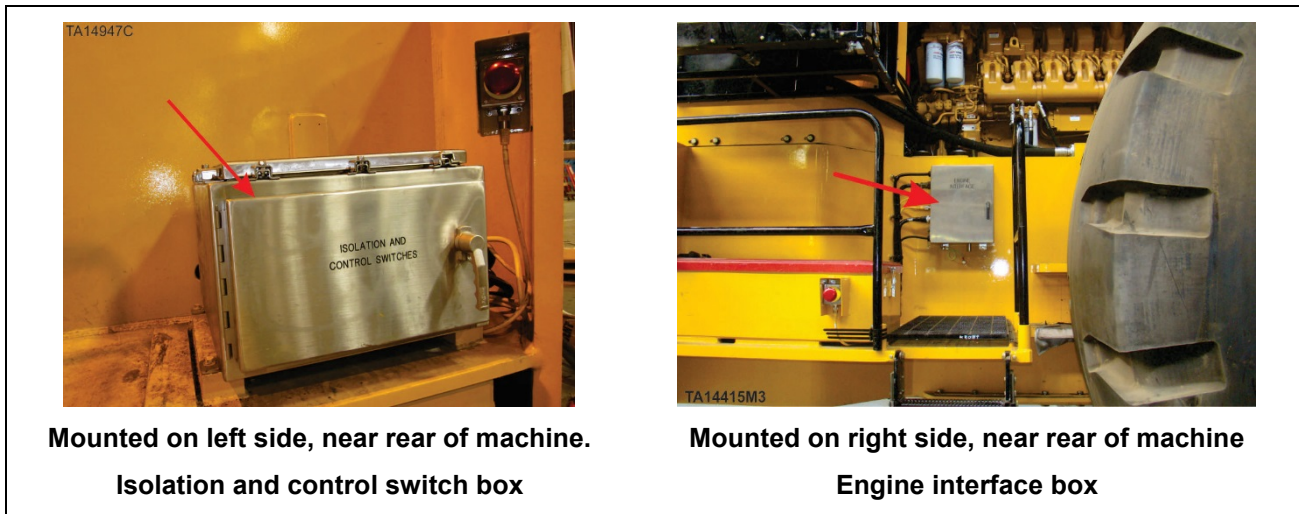

Figure 32. Isolation and control switch box and engine interface box typical locations

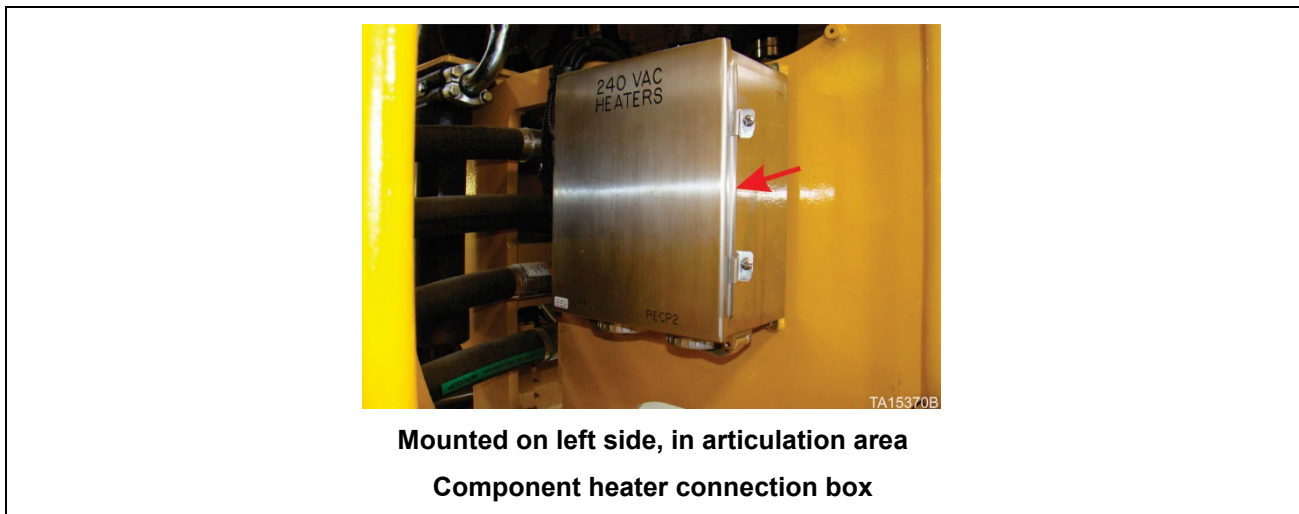

Figure 33. Component heater connection box

## CAUTION

Electrical enclosures should be opened and cleaned with a vacuum cleaner as required for dusty conditions. Enclosures exposed to extremely dusty conditions should be cleaned more frequently as determined by severity of conditions. Failure to do so could result in equipment damage.

Typical enclosures that require internal cleaning include:

- Low voltage control cabinet
- Isolation and control switch enclosure
- Engine interface enclosure
- Component heater connection enclosure
- Auxiliary steering electrical enclosure

## Front and Rear Axle Vents

DO NOT spray water or steam into the front and rear axle vents. Damage to drive motors and brakes could result.



Figure 34. Typical axle vent front frame



Figure 35. Typical axle vent



Figure 36. Typical axle vent rear frame

## Solenoids and Cable Breakout Boxes

Solenoids and breakout boxes are located in many places inside the front and rear frames. They can tolerate washing but DO NOT direct the full force of a hot water high-pressure washer or steam cleaner directly at them.

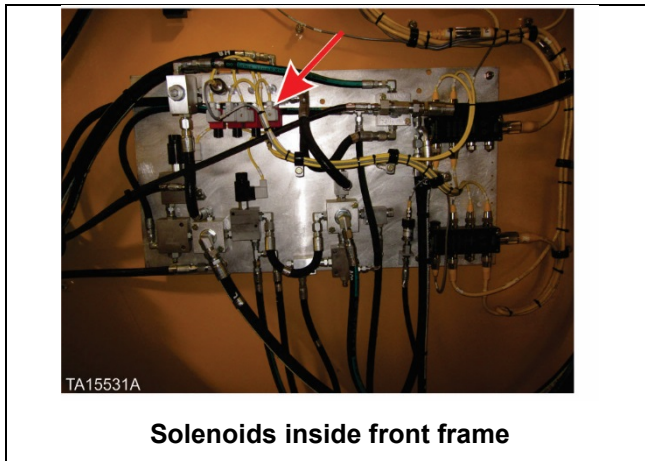

Figure 37. Typical solenoid location

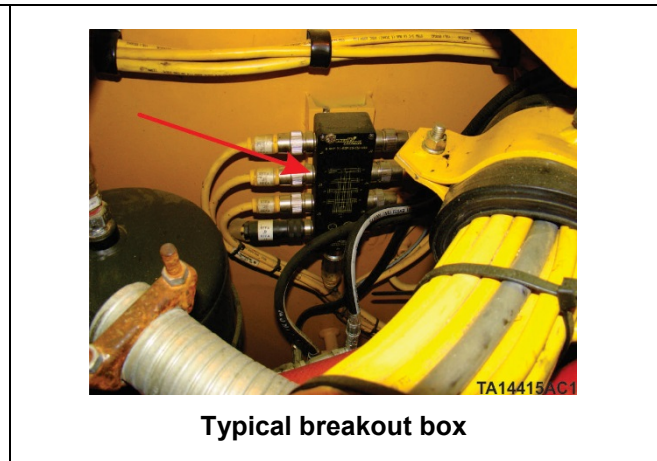

Figure 38. Typical breakout box

## KLENZ™ Air Filtration System

When washing the machine, DO NOT spray high pressure water or steam into the air intake of the KLENZ™ Air Filtration System. Water will soak and clog the filters rendering them unusable. Cover the opening with a tarpaulin or plywood etc.



Figure 39. Typical KLENZ™ air intake area



Figure 40. Typical KLENZ™ filters

# CAUTION

The KLENZ™ Air Filtration system mist eliminator panel requires periodic cleaning after several hours of operations in wet conditions. The panels require removal from the unit for cleaning. DO NOT attempt to clean the panels inside the unit, as damage to the filter elements may result. Refer to Section 05 “AIR SYSTEMS” in the Service Manual for instructions on removing the mist eliminator panels.

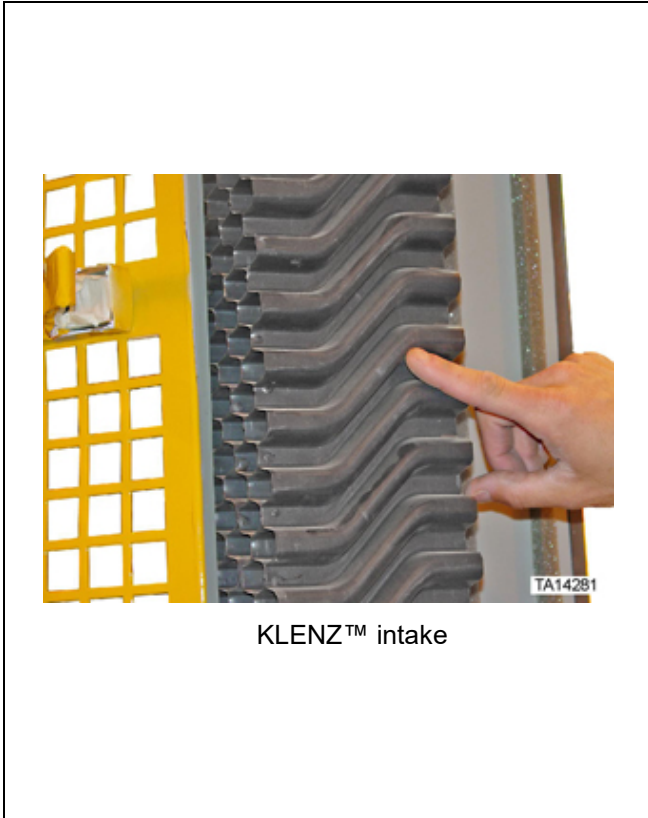

Figure 41. Typical KLENZ™ air intake area

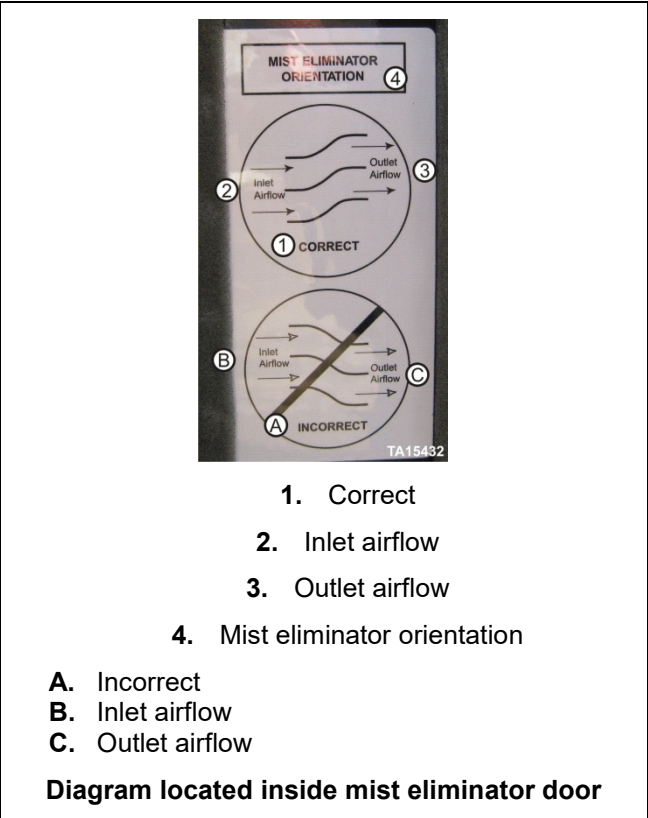

Figure 42. Typical KLENZ™ filters

### Safety and Instructional Placards/Labels

When washing the machine be careful not to damage safety or instructional placards. Use a cloth, soap, and water to clean them. DO NOT use a steam cleaner, solvent, or a hot water high-pressure washer to clean safety placards. The possibility of the placards being hidden under dirt or grease may make inadvertent damage possible. Replace any placards that are damaged, deteriorated, or illegible as soon as possible. Refer to the Parts Manual to order replacement placards.

### Powered Access Ladder (Local Option for Some Models)

DO NOT direct the full force of a hot water high-pressure washer or steam cleaner at the powered access ladder's control box. Component damage is possible.

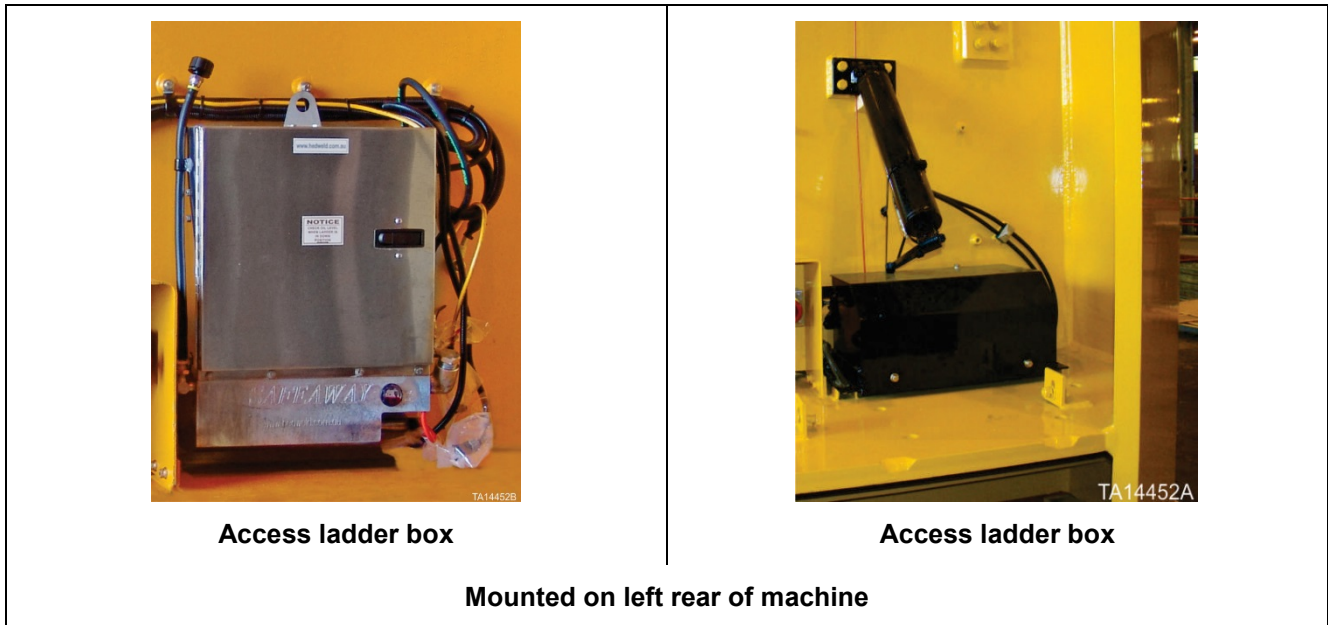

Figure 43. Typical powered ladder control boxes

### Backup Alarm and Cowl Light Junction Box

DO NOT direct the full force of a power washer or steam cleaner into the face of the backup alarm or the seal of the cowl light junction box. Component damage could occur.

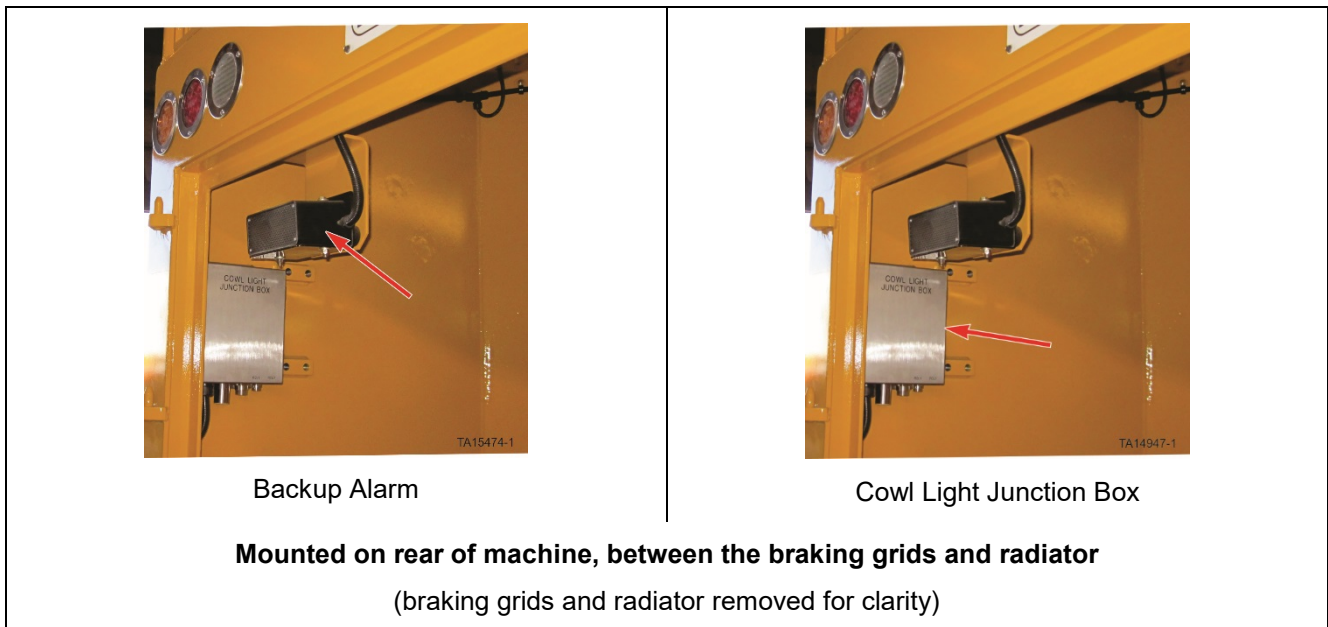

Figure 44. Typical cowl/radiator area

## Energy Storage Devices (ESDs)

Clean around the ESDs. The ESD is an electrical motor with a flywheel attached. It should be cleaned with the same precautions as an electrical motor.



Figure 45. Typical ESD

## CAUTION

**DO NOT** direct the full force of a power washer or steam cleaner into the air vents of an ESD. Component damage is possible.



Figure 46. Typical ESD air vent location

## Cleaning the Electrical Converter Cabinet and Axle Interior

As part of the 500 hour electrical system preventive maintenance program, it is recommended that the Electrical Converter Cabinet be cleaned out with clean dry compressed air or a powerful vacuum cleaner.

It is also important to remove axle access panels and cleanout accumulations of dust inside axles as part of the 500-hour electrical preventive maintenance.

### WARNING

Fire or electrical hazards exist when there is a buildup of combustible dust in any electrical compartment. It is critically important to remove any accumulation of combustible or conductive material as part of the electrical system preventive maintenance program and the cleaning program. Failure to remove accumulation of combustible or conductive material can result in fire or electrical hazard resulting in serious injury or death.

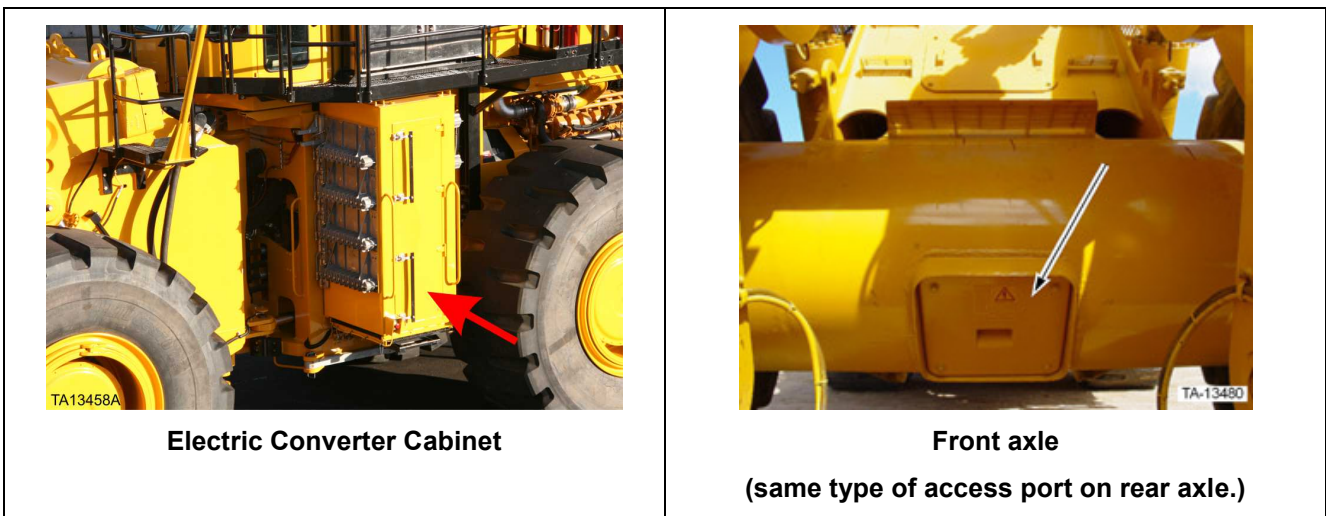

Figure 47. Shock hazards

### WARNING



Electrical shock hazard exists if inspection or service procedures involve contact with any component of the electrical system, opening the electrical converter cabinet or removing axle access covers. **NEVER** remove axle access panels unless electrical system is locked out. Do not touch electrical components unless the electrical system is locked out. Always verify the absence of bus voltage before removing axle access panels or entering the electrical converter cabinet. **NEVER** open the Electrical Converter Cabinet while the engine is running. High voltage is present when machine is at high throttle, and can be present at low throttle or up to five minutes after the machine engine is shut down. Accidental contact with energized terminals could cause an electrical shock resulting in serious injury or death.

## Clearing Drain Holes in the Operator Cab Structure

The compartment at the bottom-rear of the operator's cab contains the electrical connections between the internal cab electrical system and the external loader electrical system. The electrical connections are subject to failure if they are covered with moisture. Water damage can occur if the compartment drains are not working properly and there are leaks in the air conditioner evaporator drain or the climate control heater system. Water can also enter if the compartment cover gasket is damaged or if the cover bolts are not tight.

There is a drain on each side of the back of the cab. It is important to ensure that the compartment drains are unobstructed to prevent electrical system problems resulting from water damage to the cab rear DIN rail. It is recommended that the drains be checked every 500 hours by either removing the back cover on the bottom of the cab, or by running a pipe cleaner up into the drain tube.

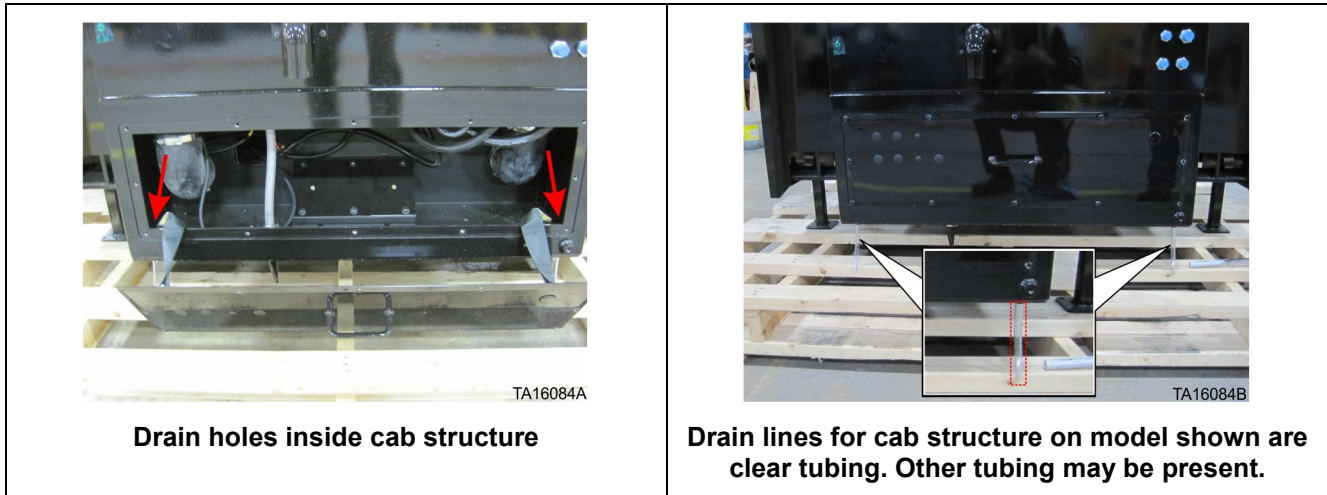

Figure 48. Typical drain holes in cab structure

## NOTICE

If a pipe cleaner is used, do not extend it any farther than is necessary to go into the hole opening to which the drain tube is attached.

## After Washing the Machine

Open the Electrical Converter Cabinet and check that no water entered into the cabinet during washing. If water is present it must be removed and the components thoroughly dried before starting the engine.

If there are ANY alarms after starting the engine, following washing, they must be corrected before returning the machine to service.

### NOTICE

**If a LINCS alarm for impedance low occurs, the probable cause is water on the braking grids. Should this occur, first perform one of the following procedures:**

- **Preferred method:** Set the machine into the load bank mode. This requires maintenance level or above. The following steps are required to set up for load bank:
  - a. Park brake must be set.
  - b. Go to high throttle.
  - c. Silence the impedance low alarm by pressing the acknowledge button.
  - d. Access the LINCS menu in maintenance mode.
  - e. Select system setup.
  - f. Enable load bank.
  - g. Lightly press (<30% pedal depression) on the accelerator and maintain a light amount of engine load. If the impedance fault is caused by moisture on the grids, the yellow light will go out as the grids dry out.
- **Non preferred method:** Operate the machine normally. The alarm condition does not disable the drive system. It is not recommended to operate longer than 30 minutes without further investigation into the alarm condition.
  - a. Move the Frame Lock to the unlocked position.
  - b. Release the Park Brake and try to propel the machine.

If after trying these procedures a low impedance fault reoccurs, the problem must be corrected by a qualified technician. Additional information on ground fault is provided in Section 06 "SR Drive System" in the Service Manual.

### CAUTION

**Move the frame lock to the unlocked position before the machine is moved or serious damage to the machine can occur.**

### NOTICE

**When finished with the cleaning procedure, follow all local rules and regulations to return the machine to operating condition.**

This Page Intentionally Left Blank